

Spark
H O L L A N D



Better Sample Care.



> sparkholland.com



“OEM is in our genes. Modifying our technology to OEM partners’ wishes has become second nature to us.”

› Florian van der Hoeven
President Spark Holland

Welcome at Spark Holland!

Your full-service OEM partner for sample preparation instruments

Over the past four decades, we have become a global leader in liquid handling and sample preparation. This is made possible by the strong partnerships we have with our OEM partners. Whether you are looking for a branded standard instrument or want to integrate our technology in your product, it’s all possible. It is our passion to really understand your challenges and work closely together to design and develop innovative technology that integrates seamlessly with your products. The many patented products we developed over the years, exemplify our way of working.

Thanks to our team of experts, we are also able to tailor all related services to the needs of our OEM partners. Why? Because we understand that it takes more than only technology to make your solution a success. From training and support of your personnel to management of the supply chain and production of promotional materials. We go all the way! And all for the commitment that characterizes Spark Holland as a company: better sample care. We look forward to working with you - our OEM partner - to take the next step in your journey.



 **Product
Overview**



Better sample care

As a supplier of analytical systems for the modern laboratory you want to have world class technology for liquid chromatography that seamlessly integrates into your products. You have come to the right place!

Spark Holland is the expert in liquid handling and sample preparation for liquid chromatography. We design and engineer high-performance autosamplers, pumps, ovens and other automated liquid handling modules. Every day we improve the process of liquid chromatography. Always going one step further. More exact, easier, better. We deal with all your analytical challenges, never

making concessions. Even if that means adapting existing systems or developing completely new ones. Spark Holland has a reputation to uphold when it comes to customer service and the integration of our knowledge and technology into 'larger' systems. Achieving the highest standard in reliability and integrity.

“A passion for the continuous improvement of LC instruments.”



Lifespan endurance testing



Spark Holland

Founded in 1982 in The Netherlands, Spark Holland has a long track record in the development of innovative and patented technology for sample preparation and liquid chromatography systems. Dutch craftsmanship delivered worldwide.

Better sample care is about the small things that matter so much. Therefore, we have always been a pioneer in innovation, developing ground-breaking products. Like our UHPLC pumps that deliver ultra-precise gradient flow. Or our autosampler technology that guarantees very secure injection, and offers real time monitoring and diagnostics to optimize performance and predict possible failures. And we are very proud of our revolutionary DBS

autosampler for dried blood spots and dried matrix spots, that enables easy sample collection, transport and storage. Spark Holland has more than 30,000 autosamplers and over 1,500 automated online SPE systems in operation worldwide. Our personal approach, know-how and flexibility make us the OEM partner of choice for many manufacturers. From early-stage research and design to development and delivery.



“A rich history in sample preparation and liquid chromatography systems.”



OEM Liquid Chromatography

Flexibility is what you expect from your OEM partner and that is what we offer with multiple ways of co-creation. From branding our standard products with your corporate identity to fully integrating our technology into your instruments. Working closely together on all aspects of product design, development and delivery. Your product is what makes us tick!



Brand & combine

- ✓ Your branding
- ✓ Our industrial design
- ✓ Separate products

Combine & customize

- ✓ Your branding
- ✓ Your industrial design
- ✓ Combine products

Customize & integrate

- ✓ Your branding
- ✓ Your industrial design
- ✓ Integrated product

[More information about](#)



Product Overview



BETTER **SAMPLE CARE**

UHPLC Sets

An LC system is much more than just a collection of modules. Spark instruments are designed for seamless integration into sets that meet current laboratory requirements.

The perfect harmonization of electronics, software and hardware, brings many analytical advantages. Synchronization of injection, dispersion and fully integrated waste management. We do everything we can to deliver the best LC systems for the most complex situations.

Of course, we can complete your set of choice with all necessary accessories like bottles, columns, waste reservoirs and methods. So, you are ready to go!

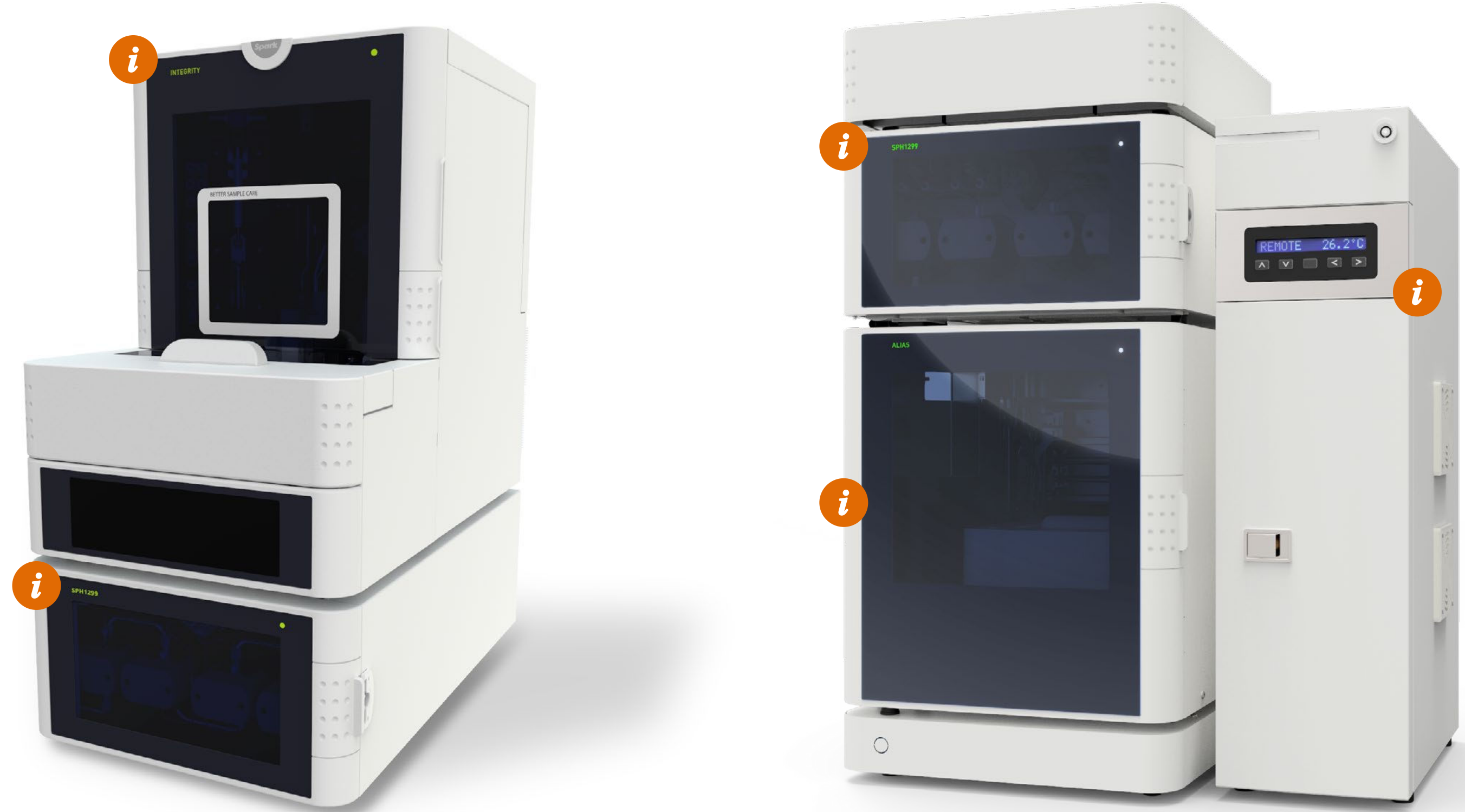

Development & Assembly

Spark Holland is well known for its work on customized solutions for high-performance systems in the analytical industry. Together with you, we bring promising ideas to life in refined technology and state-of-the-art instruments that smoothly fit into your technical workflow. Taking your business to the next level!

We act as the extension of your R&D department, focusing on front-end solutions for LC. Since we know the industry like no other and excel in elaborating technical designs, we can help you to make your instruments more intelligent. We blend in during the development process and withdraw when our product has been effectively integrated into your systems. All embedded hardware and software are developed

at Spark. For each individual engineering project, we put together a specific team of specialists. Each team member represents the qualities that Spark stands for: reliable, easy to approach, open, flexible and pragmatic, continuously focused on your goals and ambitions. We are small enough to be agile and effective, but we have the execution strength to serve industry leaders.



“From product idea to full implementation in the field.”

Feasibility testing



Your full service OEM partner

Spark Holland is more than just a technology provider. Our experienced team of professionals is there for you, during every stage of your product's lifecycle.

We understand that it takes more than good technology to make your solution a success. Therefore, we support you in every way to deliver the best possible quality and performance to your customers. From training and support of your personnel, to management of the supply chain and production of promotional materials. We go all the way!

Hardware & technology

Our highly qualified R&D team has a thorough understanding of liquid handling, pump technology, sample conditioning and integrated systems. They are used to aligning closely with our customer's project procedures when designing new products.

Industrial design

Bringing your vision and design rules together with our technology is what makes us tick! From the first visualization of concept ideas to the final implementation of a beautiful and high performing solution.



Software electronics

Together with your software development team our engineers help to develop system drivers, as well as dedicated electronics and firmware. Use of digital twin technology for simulation stimulates agile development of fast and unique algorithms.

Technical training & support

In depth training ensures that your staff are able to service and maintain instruments and systems, based on clear procedures, using dedicated preventive maintenance kits and spare parts. And of course, our service team is always available to help.





“We always seek ways to make our instruments more intelligent by using advanced analytics.”

› **Cornelis Tump**
R&D director

Supply chain management

Alignment with your forecast is key to us, so we can always deliver our products and parts on time. Our quality assurance procedures ensure we can follow a dock-to-stock policy, delivering directly to your storage or manufacturing facility.

Compliance & regulation

Our experts facilitate registration and qualification of instruments and systems by the regulatory bodies of your choice. Our quality management complies with ISO 9001 and ISO 13485 and our products are REACH and RohS compliant.

Product life cycle management

High quality products deserve a long lifetime. Therefore, we actively monitor lifetime and obsolescence to secure timely shipment of spare parts. And we deliver trouble-free, backward compatible updates under strict revision control regulations.



Analytical support

Knowledge sharing is in our genes. As a center of expertise on analytical HPLC instruments and systems, we bring the knowledge to your organization, to validate new methods, design new solutions and develop key applications.

Promotional material

Your success is our success. We do whatever we can to help you promote your solutions. From making product renderings and movies, to delivering application data and system usage examples. All Spark Holland content is available for distribution.



Your journey to success

Discover

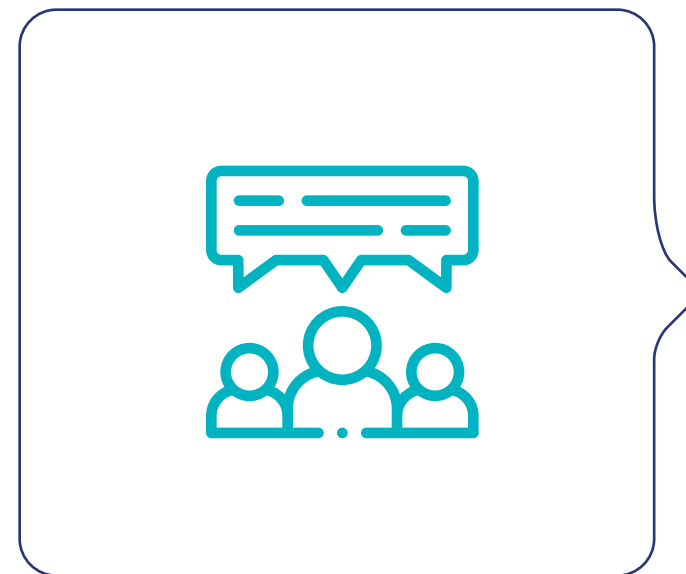

Discover

Based on your ideas and requirements, our consultants propose product concepts based on more than 30 years of industry experience.

Diagnose

During fast feasibility studies we translate product requirements into design concepts, while aligning R&D

Diagnose

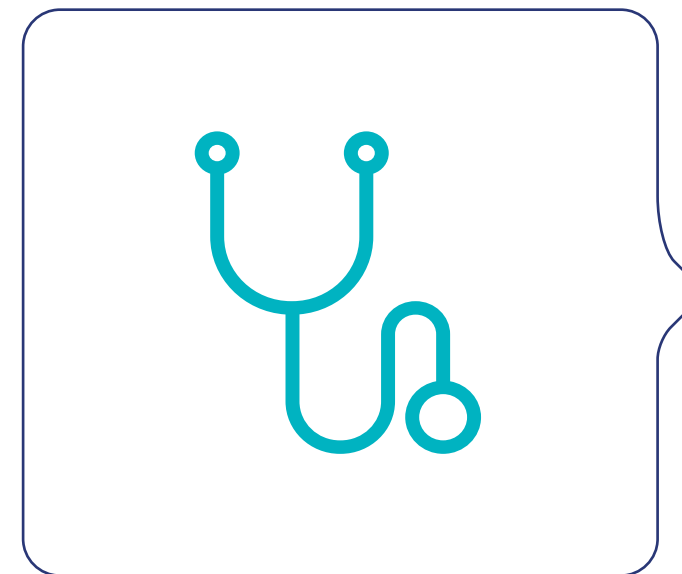

processes to ensure a smooth product development phase.

Design

The product (co-)development phase follows strict procedures in accordance with ISO13845 standard, while still leaving space for creativity. We are extremely focused on your goals and deadlines, and strive to develop intellectual

Design

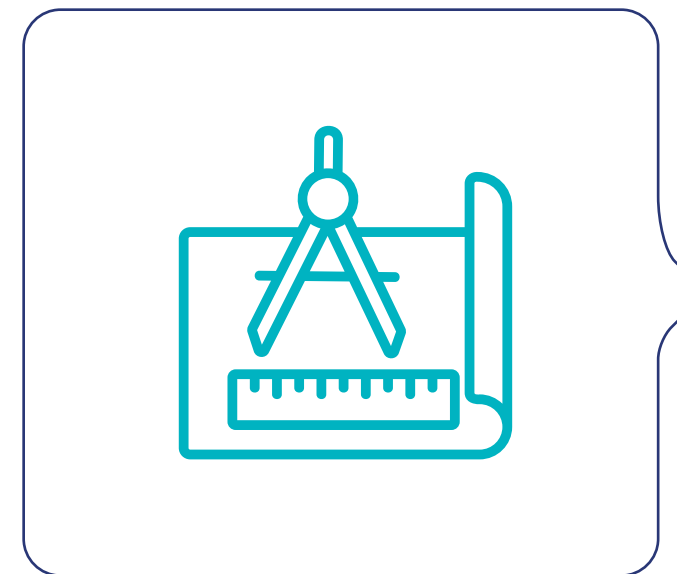

Deliver



property to gain competitive advantages.

Deliver

When product designs are ready, we implement high quality assembly lines for serial production of instruments, including services such as product life cycle management, supply chain management and technical support.



“We are laser focused on building long-term business relationships and flexible to engage in each phase of your product development process to drive commercial successes.”

› **Florian van der Hoeven**

Director commercial operations



We are here for you



It is our passion to really understand your functional and technical challenges, and to use our full expertise to translate them into innovative and feasible instruments and modules.

Jeroen Camstra
Mechanical engineering manager



Customers value our production department for always meeting delivery times, without sacrificing product quality. Our credo: we say what we do and do what we say.

Sonja van der Laan
VP operations



Our ISO9001 and ISO13845 certified quality management system ensures compliance with requirements, specification and applicable laws and regulations during the whole product lifecycle.

Henri-Paul Karman
Quality assurance manager



To ensure successful product implementation, we support you every step of the way. From installation and documentation, to spec sheets and training. We are always going that one step further.

Peter Ringeling
Product specialist



Spark Holland products



SPH1299™ V2 UHPLC gradient pump

An advanced workhorse for robust, state-of-the-art UHPLC performance and beyond. Delivering ultra-precise UHPLC gradient flow up to 1300 bar.

[Read more](#)



Mistral™ Stable and precise oven

The Mistral™ oven offers excellent temperature control, with its forced air oven, integrated solvent pre-heater and automated column selection.

[Read more](#)



SPH1299Q™ V2 UHPLC quaternary gradient pump

Based upon our proven SPH1299™ technology, this pump is the ultimate method development tool for demanding UHPLC applications.

[Read more](#)



Integrity™ Advanced autosampler

This autosampler sets a new standard in sample care. A number of innovative features ensure better and safer control of handling and tracking of samples.

[Read more](#)

[More products](#)



[Product Overview](#)



Spark Holland products

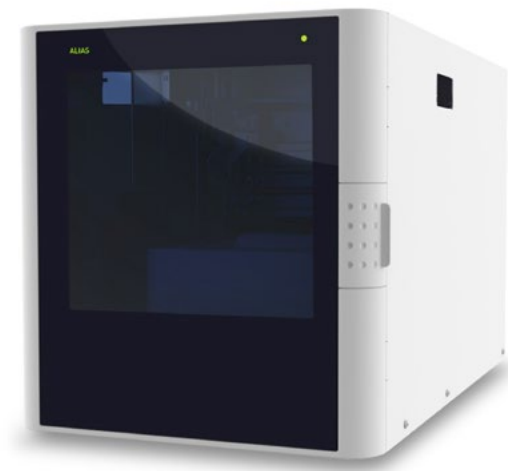

Alias™

Generic autosampler for HPLC and LC-MS

This autosampler offers state-of-the-art injection technology with fast injection and wash cycles. Efficient, multi-solvent needle wash virtually eliminates carry-over.

[Read more](#)

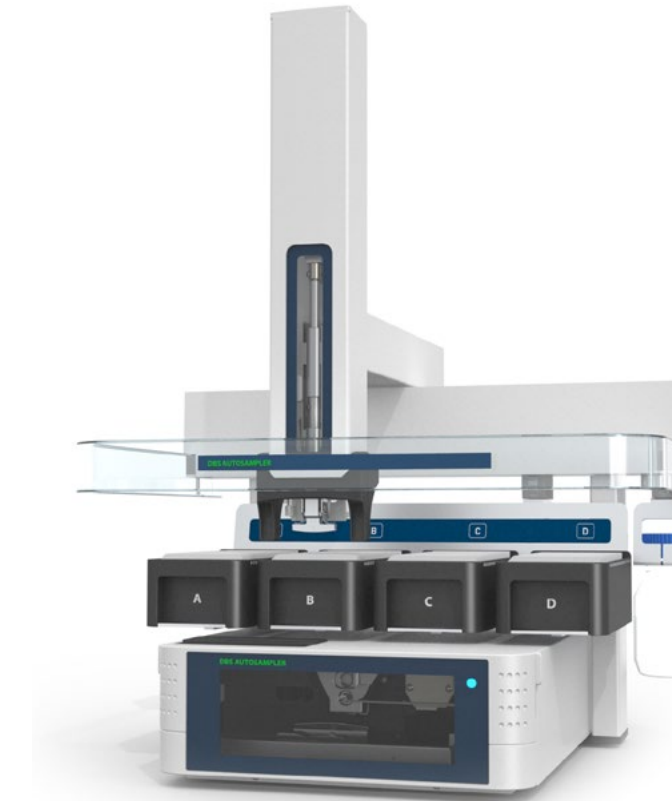

DBS Autosampler™

Dried blood spot sampling

The revolutionary DBS Autosampler™ provides easy sample collection, transport and storage, and maintains the integrity of the sample through automation, offering time and cost savings.

[Read more](#)



HPD™

High Pressure Dispenser

This very accurate and precise High Pressure Dispenser is designed for SPE solvent delivery in on-line SPE-LC systems, but other applications are easy to imagine.

[Read more](#)

[More products](#)



Product
Overview



SPH1299™ V2

Robust, precise and easy to use

UHPLC Gradient Pump

The SPH1299™ V2 UHPLC pump is an advanced workhorse for robust, state-of-the-art UHPLC performance and beyond. Delivering ultra-precise UHPLC gradient flow up to 18,850 psi (1300 bar). Featuring truly automatic compressibility compensation, real self-priming and clearing plus simple maintenance, this pump will turn users into friends.

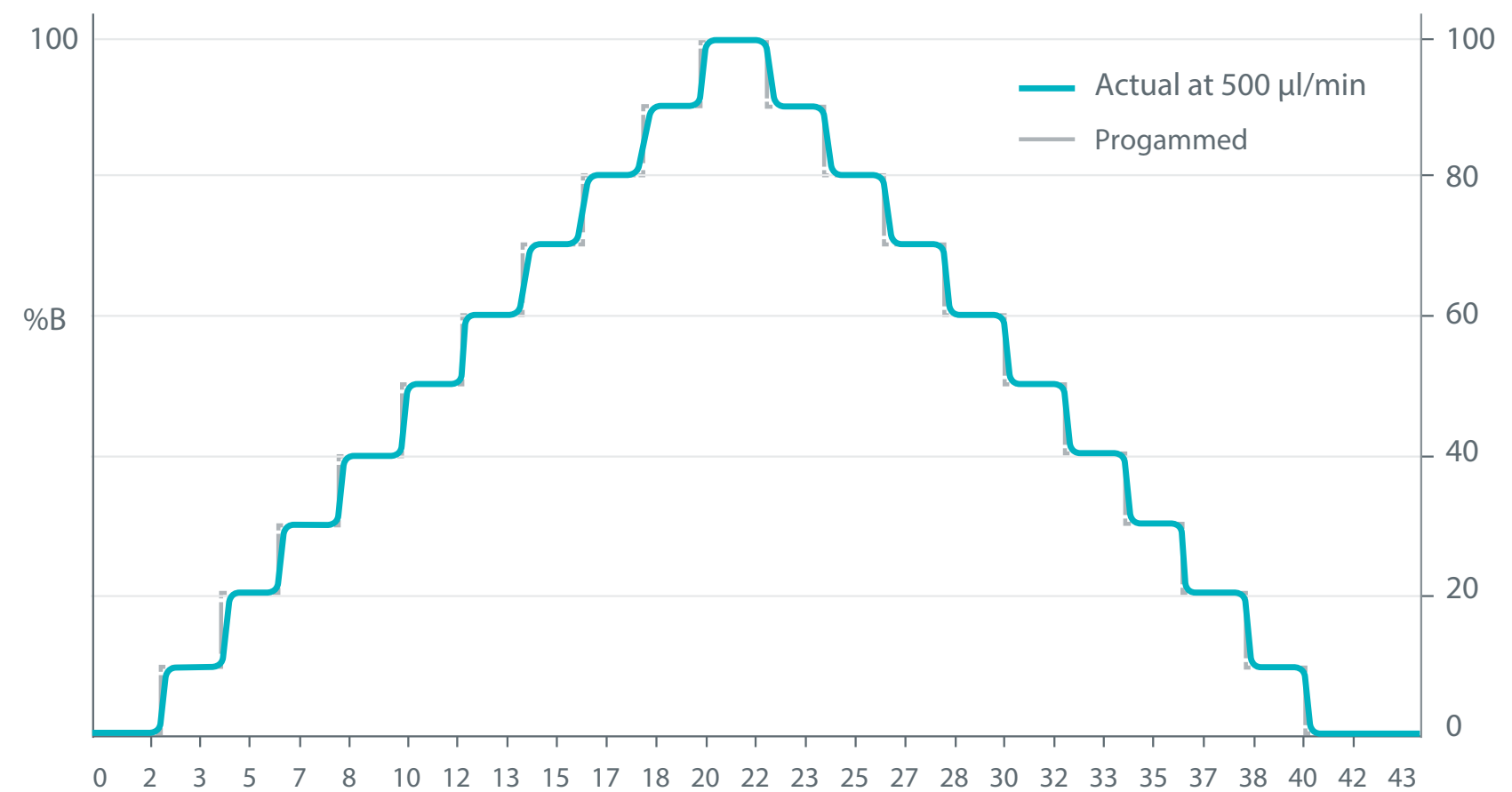
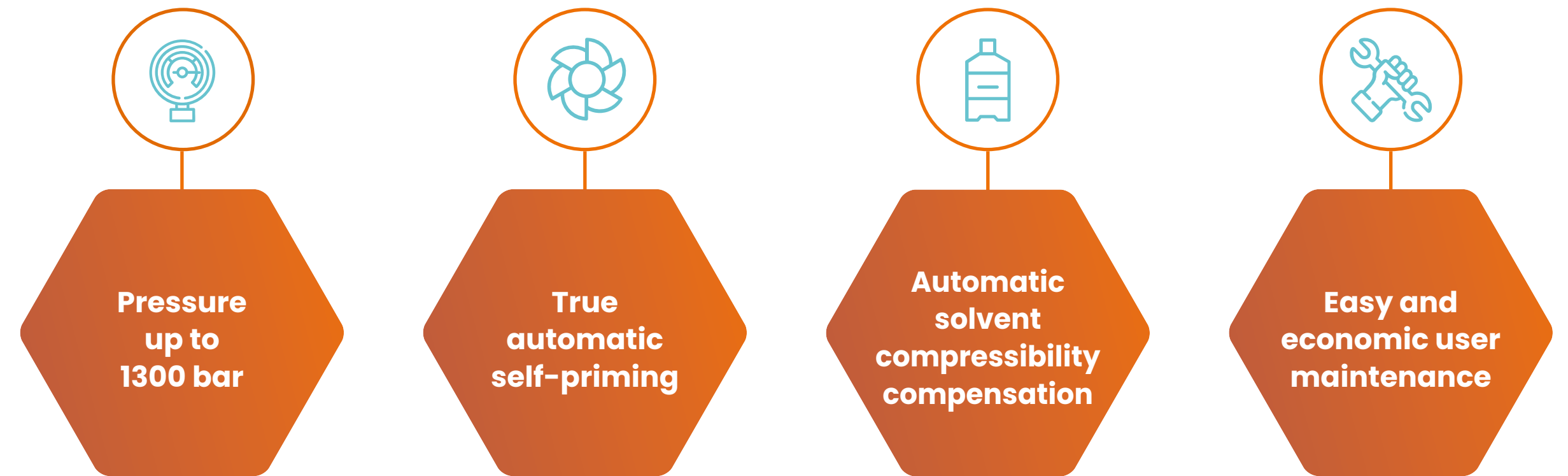

Rapid gradient response enables accurate control of steep gradients for ultra fast separations



Product Overview



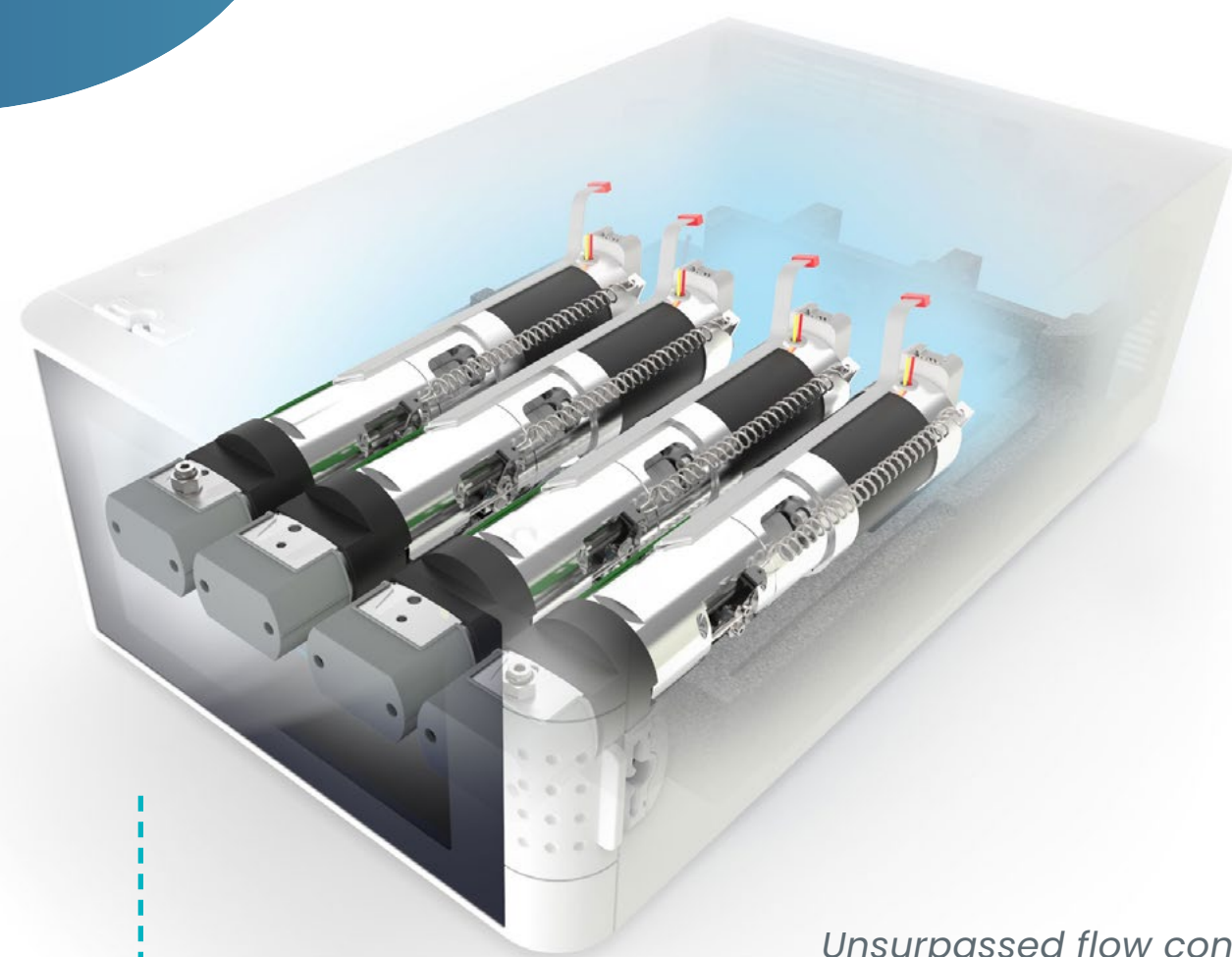

Unsurpassed flow control with individual linear drives for all pump heads

Reliable performance

SPH1299™ V2 is based on the reliable, proven concept of linear drive technology for two pairs of serially coupled pump heads. Each of the four pump heads, which are completely made of high quality 316 stainless steel with a high tech coating, is individually driven and controlled. This generates maximum freedom for flow control and pulse reduction. With intelligent novel flow control algorithms this freedom has been fully explored to create a stable and accurate flow, independent of solvent compressibility, pressure and flow rate. This results in solvent gradients with exceptional precision of both the solvent composition and the flow rate; i.e. in robust and precise gradient UHPLC. Furthermore, to reduce polymer residue built-up one can, in addition to the standard Sapphire seat, opt for a Zirconia seat.

Easy and economic user maintenance

SPH1299™ V2 has active piston backwash for longer lifetime of piston seals. This is very effective to increase up-time of the pump, but eventually a seal will need replacement. With this in mind, the pump head has been designed to facilitate easy disassembly and seal exchange. No need to remove covers or take the pump out of the UHPLC stack. No need, also, for expensive exchange of entire pump head/drive assemblies! Simply disconnect the pump head from its drive, remove the piston and replace the seal. In just minutes! In addition, optimal force distribution on the seal prevents possible breakage of the check valve.

The autonomous diagnostic tool, reading sensor data in real time at 1,00 Hz, makes troubleshooting easier and saves a lot of maintenance time.

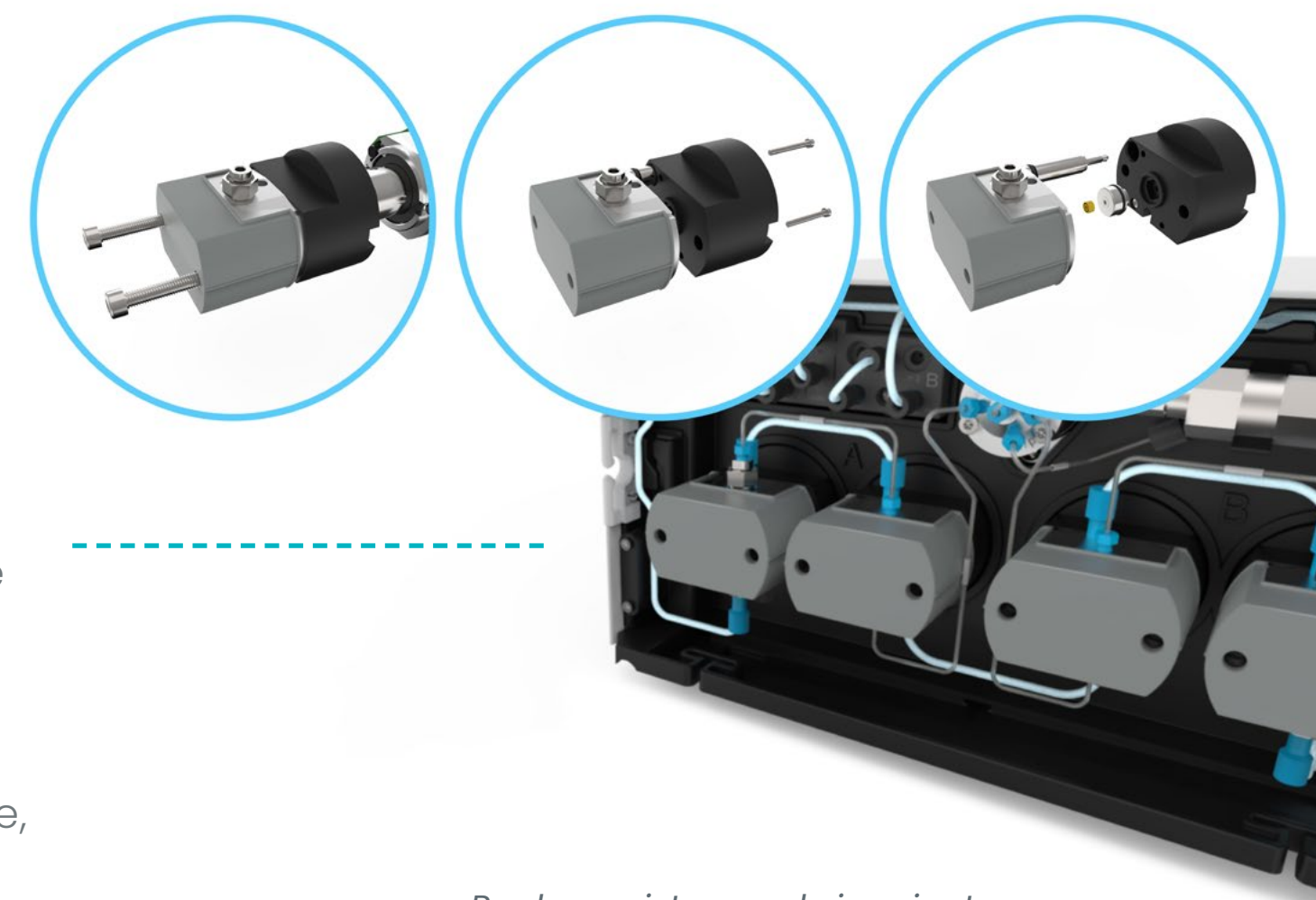

Replace piston seals in minutes

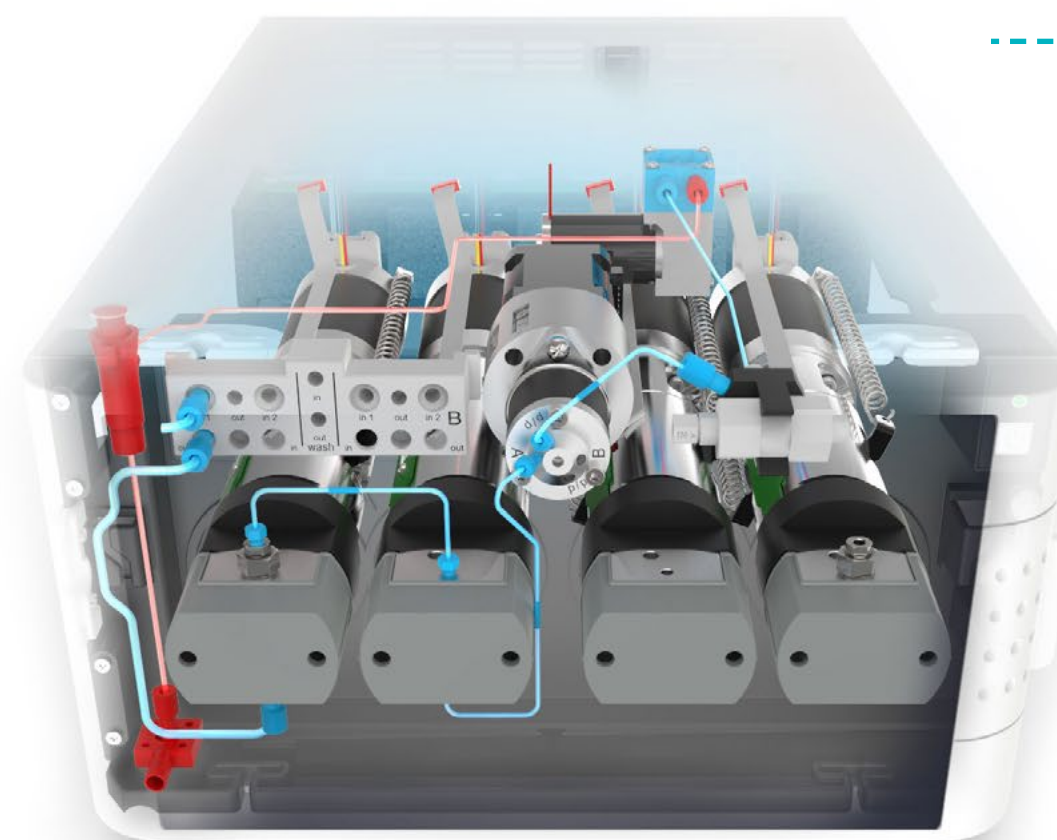

Rapid automated self-priming with the integrated prime pump

True automatic self-priming

A novel automatic priming concept fully automates the cumbersome priming procedure. A built-in prime pump aspirates solvent through the pump heads when starting with empty solvent inlet lines. No need to help your pump with a syringe for awkward manual solvent aspiration. Using an electrically actuated purge valve, SPH1299™ V2 can truly prime and purge all by itself in just a few minutes!

Specifications

Pressure	
Pressure range	0 - 1300 bar / 0 - 18,850 PSI (0 - 2000 µL/min)
Pressure ripple	0 - 1300 bar / 0 - 18,850 PSI (0 - 2000 µL/min)
Flow	
Flow range	1 - 4000 µL/min
Flow resolution	1.0 µL/min increments
Flow precision	≤ 0.075 % RSD or 0.005 minutes SD whichever is greater (water flow range 0.200 - 2.000 mL/min)
Flow accuracy	± 1 % or ± 10 µL/min whichever is greater (water flow range 0.200 - 2.000 mL/min)
Gradient	
Gradient range	0-100 %
Gradient composition accuracy	± 0.5 % absolute from 5-95 % (flow range 0.200 - 2.000 mL/min)
Gradient composition precision	≤ 0.15 % RSD or 0.01 minute SD, whichever is greater (flow range 0.200 - 2.000 mL/min)
Gradient delay volume	50 µL when using 35 µL mixer
Gradient profiles	Linear, concave and convex; 4 of each
Options	
Check valves with a zirconia seat to minimize polymer residue build-up	
High-tech pump head coating for demanding applications	
10,000 psi (690 bar) or 18,000 psi (1240 bar) solvent delivery system	
PEEK tubing to minimize background in PFAS applications	



SPH1299Q™ V2

Linear driven quaternary pump

For fast and easy method development

The SPH1299Q™ V2 is a linear driven quaternary pump that easily meets contemporary requirements of modern laboratories. Whereas high pressure gradient pumps - like the SPH1299™ - are known for their ultra fast gradients and low dwell volume, low pressure gradient pumps excel in flexibility. Blending up to four solvents with excellent performance enables easy and fast method development. Next to this, method transfer and application switching are easy and straightforward, which makes the SPH1299Q™ V2 the preferred pump for many laboratories. The autonomous diagnostic tool, reading sensor data in real time at 1,00 Hz, makes troubleshooting easier and saves a lot of maintenance time.

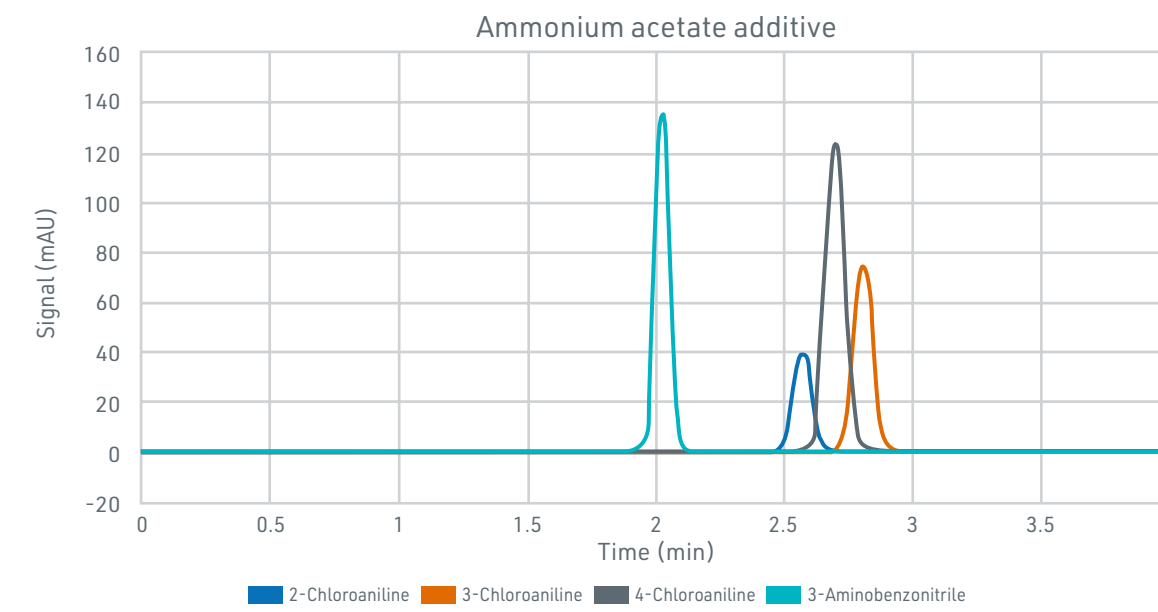
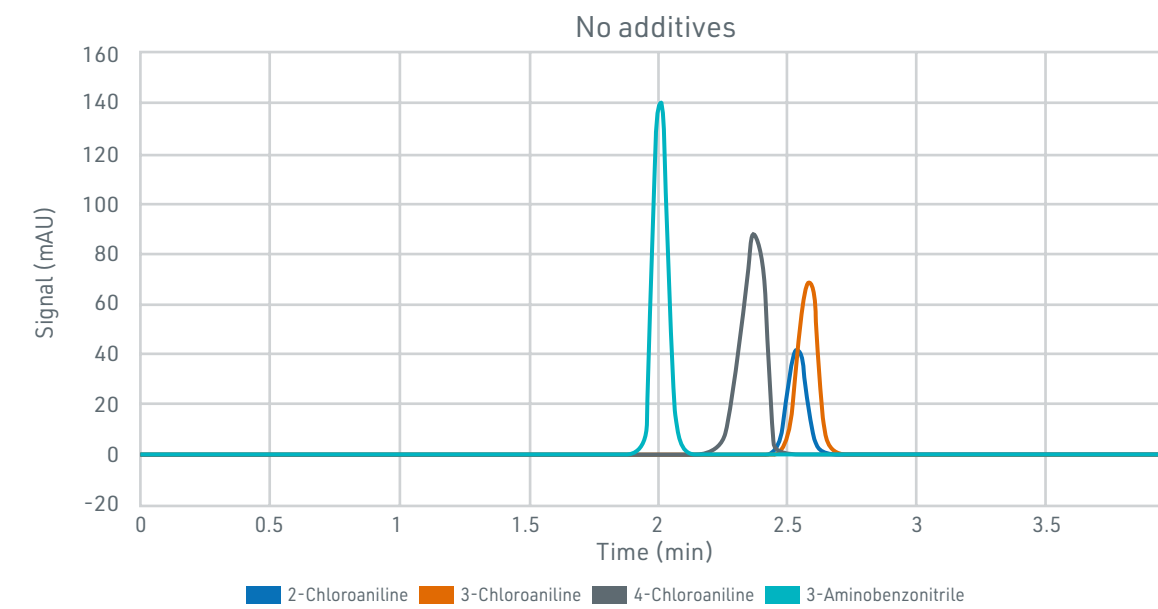

One of the key elements of the SPH1299Q™ V2 is the ability to create different mobile phase mixtures easily. These chromatograms show the effect of adding different types of additives on the separation of anilines. (Experimental conditions: isocratic run mode, flowrate: 0.5 ml/min, 10µl injection)

Experiment	Solvent composition			
	Water	MeOH	100 MH NH4Ac	1% Formic acid
No additives	80	20	0	0
FA additive	72	20	0	8
NH4Ac additive	76	20	4	0

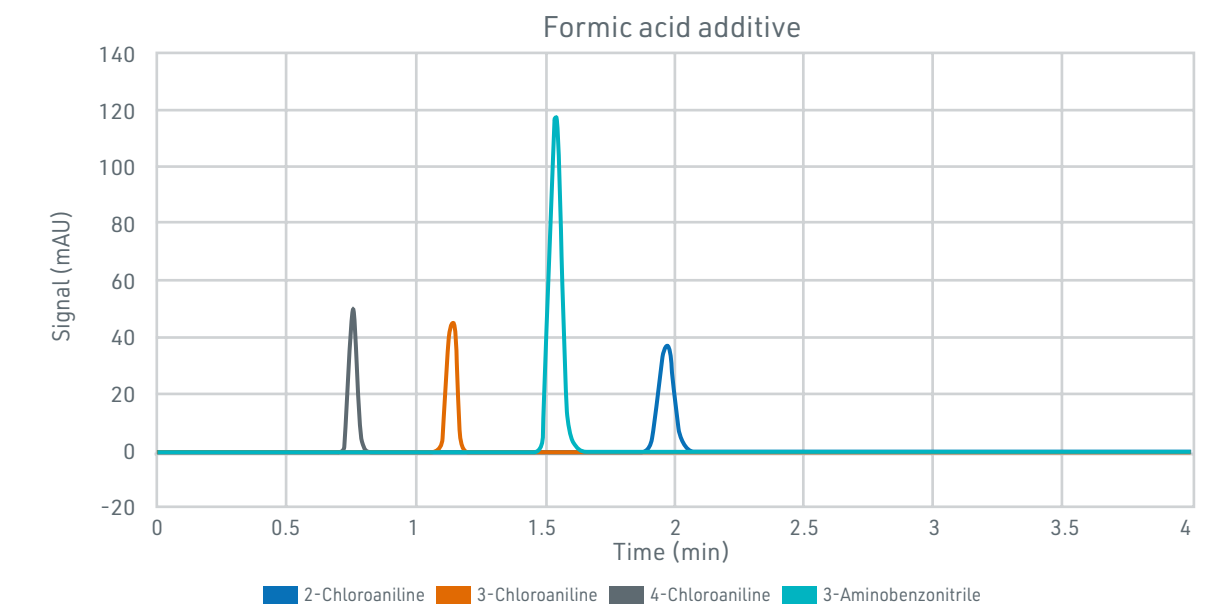

Pressure up to 1300 bar

True automatic self-priming

Automatic solvent compressibility compensation

Fast method development



The SPH1299Q™ V2 is based upon the proven technology of our high pressure gradient pump, SPH1299™ V2. All the outstanding and unique features of the SPH1299™ V2 are covered in this quaternary pump as well. By default: no manual priming and purging, accurate and precise flow control and easy maintenance.

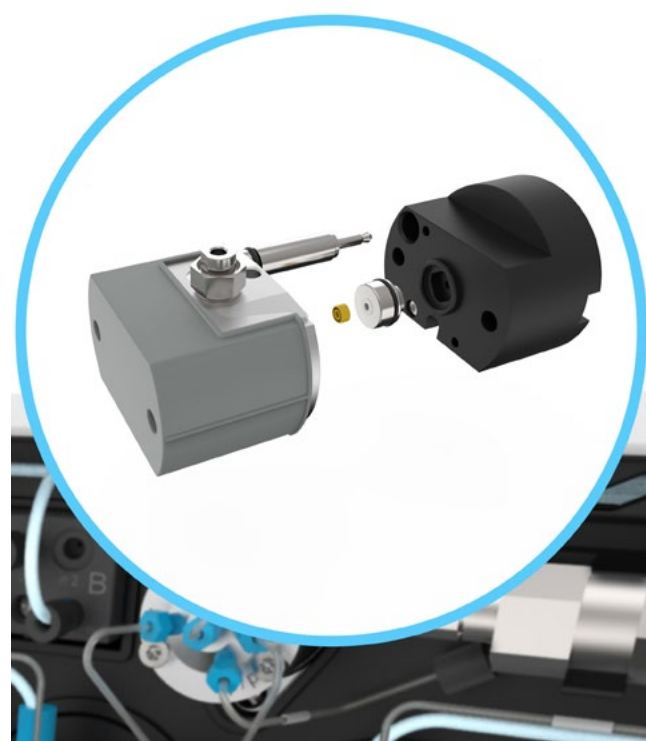
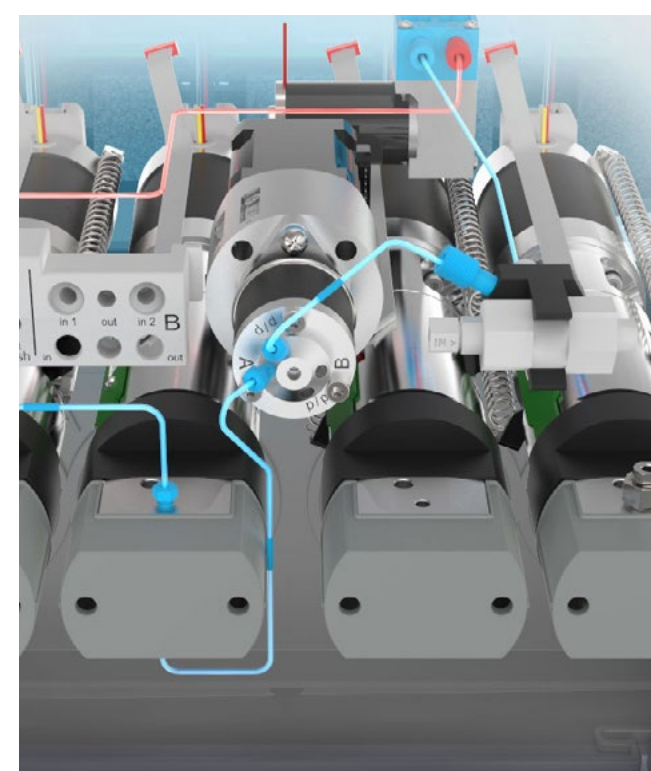

SPH1299Q™ V2 is based on the reliable, proven concept of linear drive technology. Each of the two pump heads, which are completely made of high quality 316 stainless steel with a high tech coating, is individually driven and controlled, generating maximum freedom for flow control and pulse reduction.

A novel automatic priming concept fully automates the cumbersome priming procedure. A built-in prime pump aspirates solvent through the pump heads when starting with empty solvent inlet lines.

Furthermore, to reduce polymer residue built-up one can, in addition to the standard Sapphire seat, opt for a Zirconia seat.

The pump head has been designed to facilitate easy disassembly and seal exchange. No need to remove covers or take the pump out of the UHPLC stack. And no expensive exchange of entire pump head/drive assemblies!

In addition, optimal force distribution on the seal prevents possible breakage of the check valve.

Method parameters	
Wavelength	254 nm
Injection vol.	5 µL
Column	Brownlee Pecosphere CRC18 3.3 x 3 cm, 3 µm
Sample	50 ppm phenone mixture in 10% MeOH

This application example with a fast and steep gradient, demonstrates the fast runtimes and excellent precision performance of the SPH1299Q™ V2. Just what you expect of a high-class quaternary pump.

Gradient				
	Time (min)	Flow (mL/min)	%A (Water)	%B (ACN)
Step 1	0.0	2.0	65	35
Step 2	0.1	2.0	65	35
Step 3	1.0	2.0	0	100
Step 4	1.1	2.0	0	100
Step 5	1.2	2.0	65	35
Step 6	2.0	2.0	65	35

Compound	Acetophenone	Butyrophenone	Valerophenone	Hexaphenone	Heptaphenone
Average Rt (n= 50)	0.727	1.099	1.212	1.307	1.387
Min SD	0.007	0.005	0.005	0.005	0.005

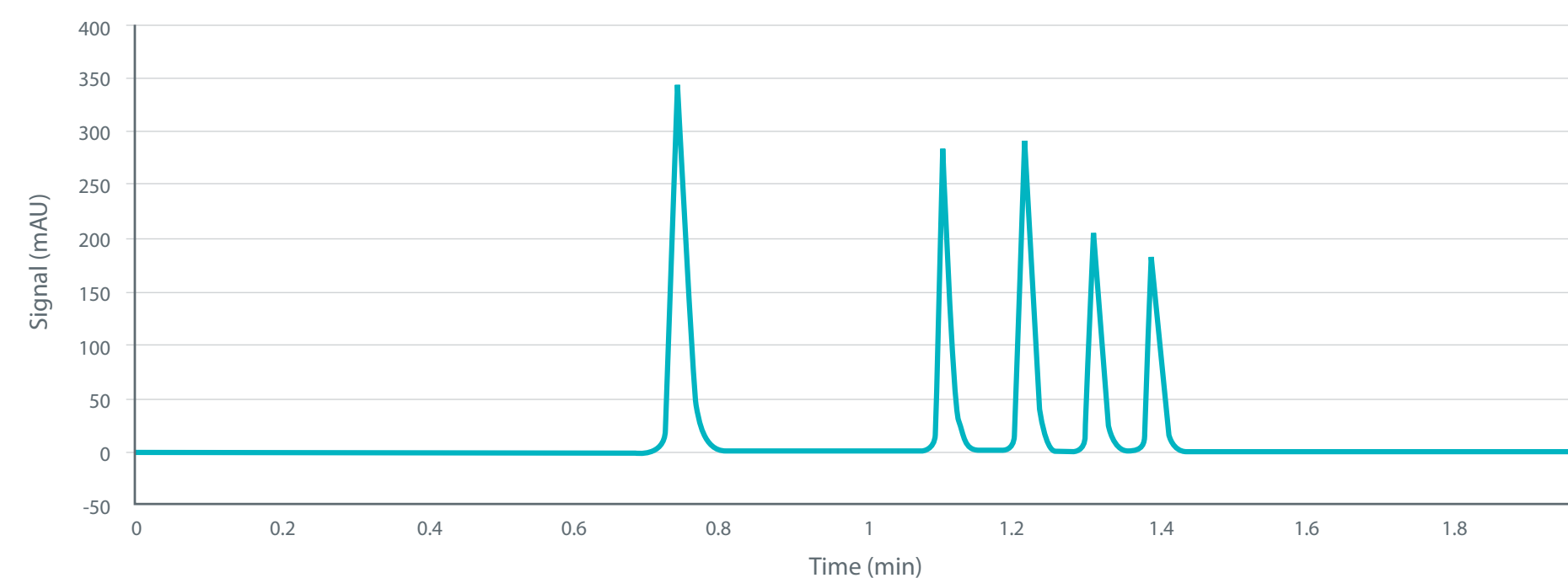

Specifications

Pressure	
Pressure range	0 – 1300 bar / 0 – 18,850 PSI (0-2000 µL/min)
Pressure ripple	< 1% of system pressure or < 5 bar, whichever is greater
Flow	
Flow range	1 – 2000 µL/min
Flow resolution	1.0 µL/min increments
Flow precision	≤ 0.075% RSD or 0.005 minutes SD whichever is greater (water flow range 0.200 – 2.000 mL/min)
Flow accuracy	± 1% or ± 10 µL/min whichever is greater (water flow range 0.200 – 2.000 mL/min)
Gradient	
Gradient formation	Low-pressure mixing
Gradient composition accuracy	±0.5% absolute (full scale) from 5% to 95% from 0.500 – 2.000 mL/min
Gradient composition precision	<0.15% RSD or 0.02 min SD whichever is greater at 0.500 – 2.000 mL/min
Number of solvents	Up to four solvents
Dwell volume	691 µL (default)
Gradient profiles	Linear, concave and convex; 4 of each
Options	
Check valves with a zirconia seat to minimize polymer residue build-up	
High-tech pump head coating for demanding applications	
10,000 psi (690 bar) or 18,000 psi (1240 bar) solvent delivery system	
PEEK tubing to minimize background in PFAS applications	





Mistral™

Stable and precise oven

Dependable temperature control for better separations

With its forced air oven, vapour sensor and integrated solvent pre-heater, the MISTRAL™ offers stable and precise temperature control to optimize your HPLC or UHPLC assay. As you will easily recognize, retention times will be more constant with constant temperature, but varying the temperature can also be of great help to tune selectivity, improve peak shape and reduce analysis time. Plus, high temperatures reduce column back pressure significantly, allowing higher solvent flow rates, narrower columns or smaller particles.



Automated
column
selection

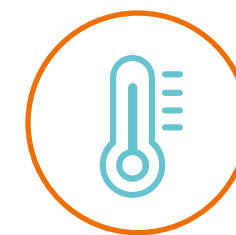

Temperature
control from
5°C – 90°C



Integrated
solvent
pre-heater

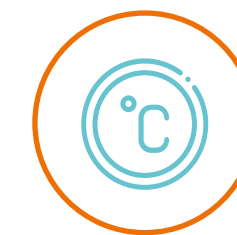

Excellent
temperature
stability



Specifications

Parameter	Value	Conditions
Temperature range	5°C – 90°C, with 1°C increments 5°C – 75°C, with 1°C increments, if optional Column Selection Valve is installed	Ambient temperature and humidity influence the lower temperature limit of the MISTRAL™. Typically, a ΔT of 18°C is feasible.
Temperature accuracy	Better than 0.1°C	Measured at 30°C in the centre of the oven compartment
Temperature stability	Better than 0.1°C	Measured at 30°C in the centre of the oven compartment
Temperature reproducibility	Better than 0.1°C	In the centre of the oven compartment
Temperature gradient	Better than 0.2°C	Measured in the column area
Temperature change	Up: 10°C/min from 40° to 60°C Down: 2°C/min from 60°C to 40°C	
Time programmable temperature change	Time base: 9hr59 total time with 1-minute increments Maximum 10 programmable steps	
Programmable temperature ramp	Up: 0.1 – 5.0°C/min Down: 0.1 – 1.5°C/min (75°C to 25°C)	It is possible to program a ramp up to 9.9°C/min; however, only the ramp ranges specified can be guaranteed for the actual temperature ramp.
Dimensions (H x W x D)	600 x 170 x 345 mm (h x w x d)	

Automated column selection

Select up to 6 different columns via the keyboard or the PC! This feature comes as an option and will be a great help for method development or if you want to run multiple assays on a single system. UHPLC valve available!

Easy fit

Extensive remote control I/O, including PC control, makes integration into your HPLC or UHPLC system an easy job. The large column area will accommodate almost any column size and the small footprint will hardly increase the bench space required by your system.



Integrity™

A new standard in sample care

Advanced autosampler

State-of-the-art injection technology, rapid sample turn-around time and large sample capacity are important, of course. But this all becomes irrelevant if you have only the slightest doubts about the integrity of the samples that you injected! Yet, while injection technology and capacity have seen great advances over the last 30 years, measures to maintain and control sample integrity have had little attention from instrument manufacturers. That's why we developed the Integrity™ autosampler.

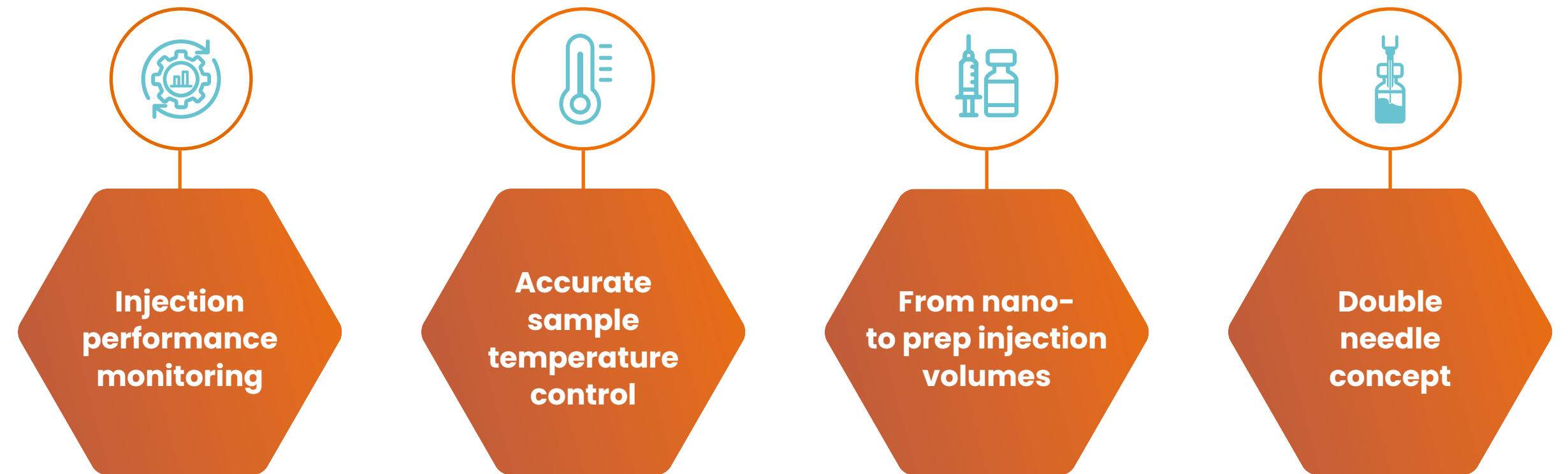
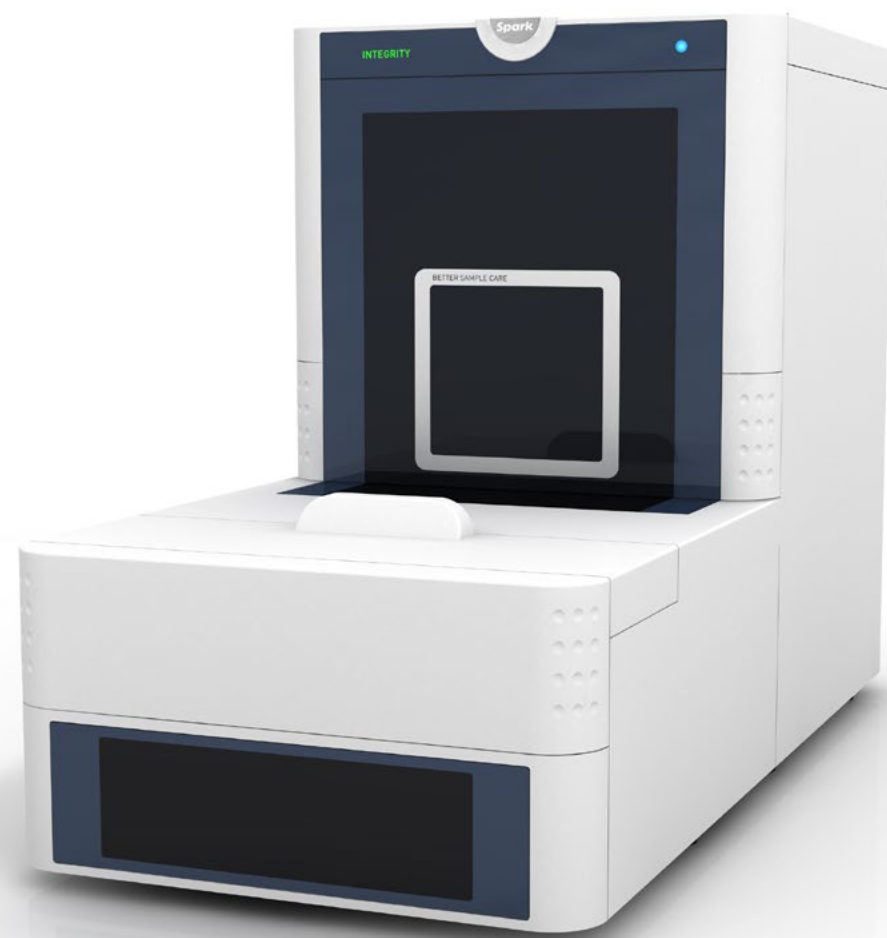

- Sample and tray bar code reading
- < 20 sec injection cycle
- True 4 °C sample cooling of all samples
- Injection performance monitoring
- Vial bottom detection – inject 1 µL out of 1 µL

- Advanced wash capabilities to eliminate carryover
- Dual independent concentric needle concept
- Optimized for UHPLC
- Advanced reagent addition and derivatization

- Integrated on-line sample prep capabilities
- Up to 4 well plates or 216 standard sample vials
- Flexible workstation for many liquid handling needs of analytical samples



Product Overview



Micro injection volumes and micro sample waste

Using a micro syringe for accurate aspiration of small sample volumes, even nanoliter volumes of samples can be injected with high precision and accuracy. The microliter-pick-up mode reduces sample loss to zero, and vial bottom detection enables INTEGRITY™ to position the sample needle at just a few tenths of a mm above the vial bottom to make sure you get all your precious sample injected reliably, independent of size variations in vials. Injection cycle time is not compromised by the reduced syringe volume because of the separate wash pump taking care of wash solvent delivery!



STC™ – Accurate sample temperature control – low and high!

Many biological samples require cooled storage during processing to avoid deterioration. INTEGRITY™ not only offers cooling, but also offers sample temperature control from 4°C up to 40°C for the entire sample tray and sample processing space. Actual readout of tray temperature shows when the autosampler is ready to accept new samples. Actual tray temperature can also be linked to sample assay results to verify correct sample temperature afterwards. And, in addition, the cooling device has been designed to reduce condensation in the sample area to a minimum.

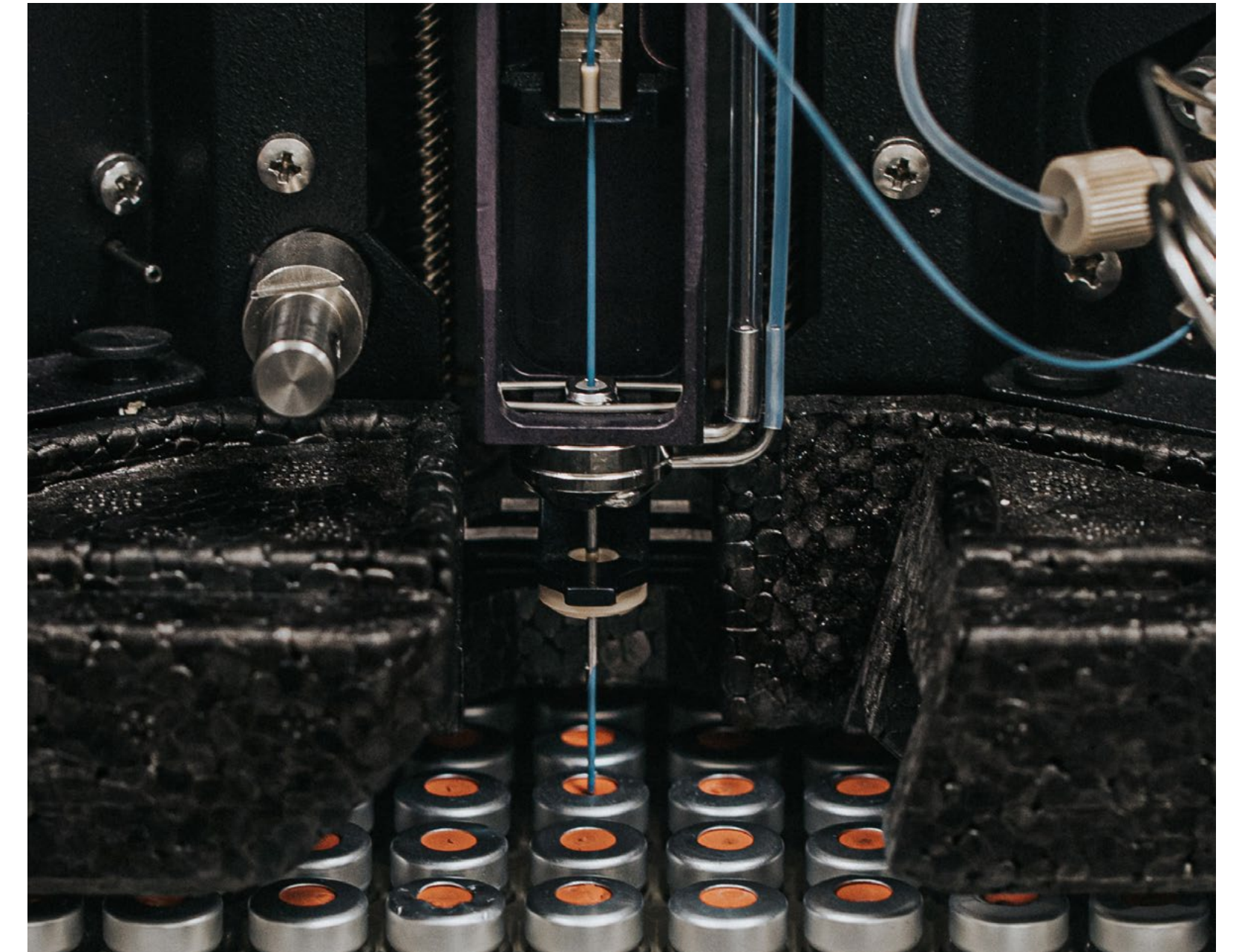

Separate needle wash pump for better needle wash and faster injection cycles

A separate built-in solvent pump provides wash solvents to the needle pair, and a smart combination of air pressure and solvent streams ensures thorough cleaning of the needle pair, inside and outside, in seconds. And also provided – jet-stream drying of the needles before entering the next sample! Multiple solvents can be selected by the wash pump for maximum clean-up ensuring zero carry-over for the stickiest samples. Because the wash pump is much faster than the syringe-dispenser used for the injection, needle rinsing is not only better, but also much faster.

Specifications

	Integrity HPLC	Integrity UHPLC	Integrity UHPLC Micro
Max operating pressure	35 MPa (5000 psi)	126 MPa (18,000 psi)	84 MPa (12,000 psi)
Loop volume	Standard: 50 µL Other loop sizes possible	Standard: 20 µL Other loop sizes possible	10 µL Other loop sizes possible
Injection volume With standard loop volume*	<ul style="list-style-type: none"> • Full loop: 50 µL • Partial loop fill: 1 – 25 µL • µL pick-up: max 15 µL <p>* larger volumes possible with larger sample loop</p>	<ul style="list-style-type: none"> • Full loop: 20 µL • Partial loop fill: 0.5 – 10 µL 	<ul style="list-style-type: none"> • 0.05 – 1 µL
Injection precision With standard loop volume	Full-loop: < 0.3% RSD Partial loop-fill: < 0.5% RSD* µL -pick-up: < 1.0% RSD* * injection volume > 5 µL	Full-loop: < 0.3% RSD Partial loop-fill: < 0.5% RSD* µL -pick-up: < 1.0% RSD* * injection volume > 1 µL	Full-loop: < 0.3% RSD Partial loop-fill: < 0.5% RSD for injection volume > 0.2 µL -pick-up: < 1.0% RSD for injection volume > 0.2 µL
Sample needle	SS 0.25 mm i.d. Volume 10 µL (including connecting tubing)	PEEK-SIL 0.2 mm i.d. Volume: 7 µL (including connecting tubing)	PEEK-SIL 0.15 mm i.d.; volume 3.6 µL
Sample buffer tubing tubing between syringe and injection valve	Tefzel, 1.0 mm i.d. Volume 500 µL	Tefzel, 0.75 mm i.d. Volume 200 µL	PEEK, 0.5 mm i.d.; volume: 100 µL
Injection valve* *) other valves available on special order	SS stator, PEEK rotor seal, 0.4 mm bore, 1/16" connections	UHPLC valve with ILD™ Coated SS stator VESPEL rotor seal 0.25mm bore 1/16" connections	Coated SS stator, VESPEL rotor seal, 0.15 mm bore, 1/32" connections.
Dispenser Syringe volume	250 µL	100 µL	50 µL
Injection cycle time	Typically 30s, including default wash in partial loopfill mode	30 – 60 sec. depending on selected conditions for injection and wash speed	~ 1 minute depending on injection and wash conditions
Carry-over	< 0.005% under specified conditions	< 0.005% under specified conditions	< 0.01% under specified conditions



Alias™

The best fit for your HPLC system

Generic autosampler for HPLC and LC-MS

ALIAS™ is a generic autosampler for HPLC and LC-MS using state-of-the-art injection technology with fast injection and wash cycles. Designed to fit any system for any application. Multi-solvent needle wash virtually eliminates carry-over. ALIAS™ handles well plates and sample vials, either open or sealed, and provides true 4°C sample cooling. Its compact, stackable design and unrivalled performance make the ALIAS™ autosampler the best fit for your (U)HPLC system.

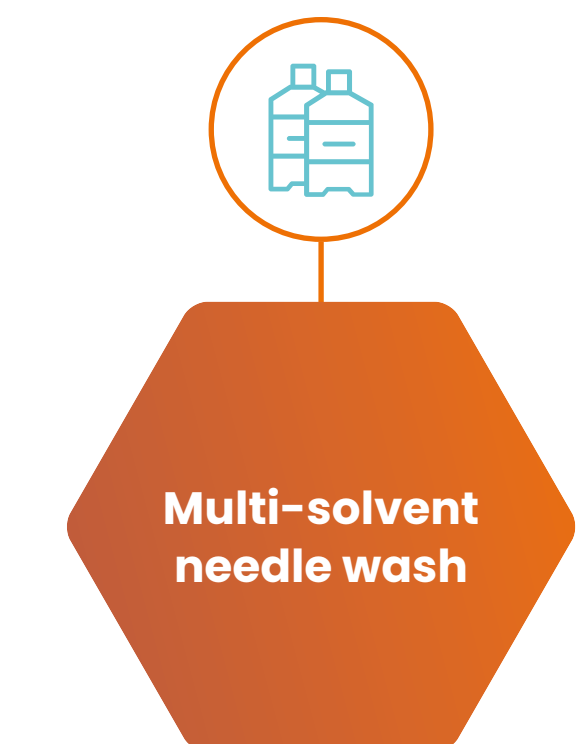
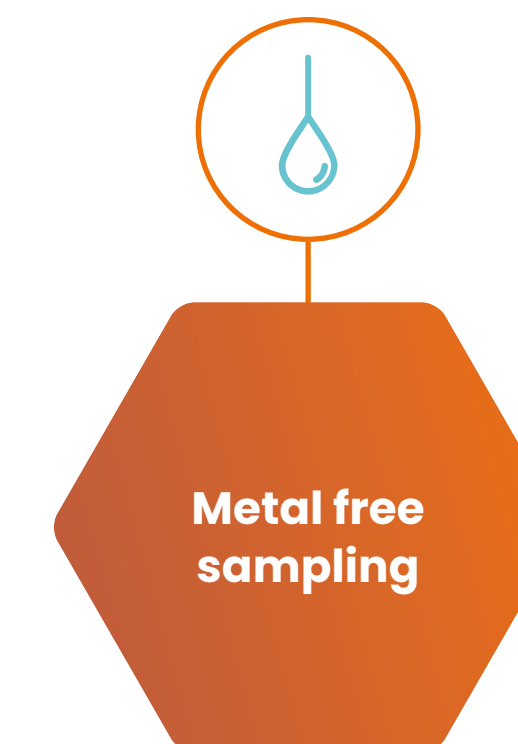
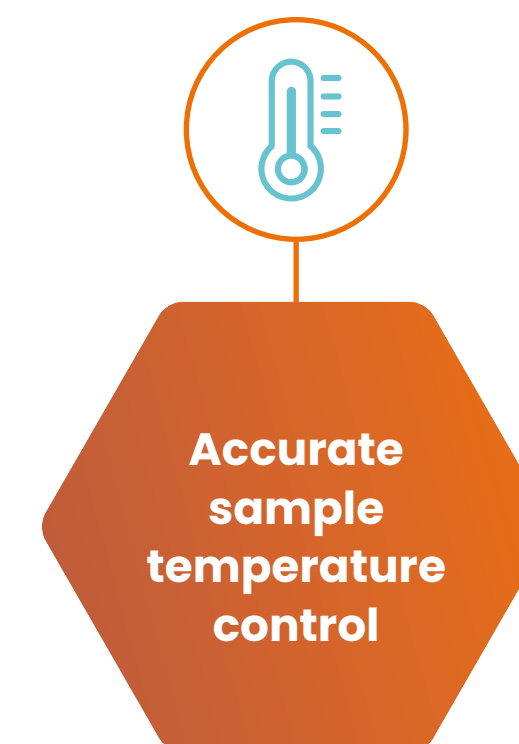
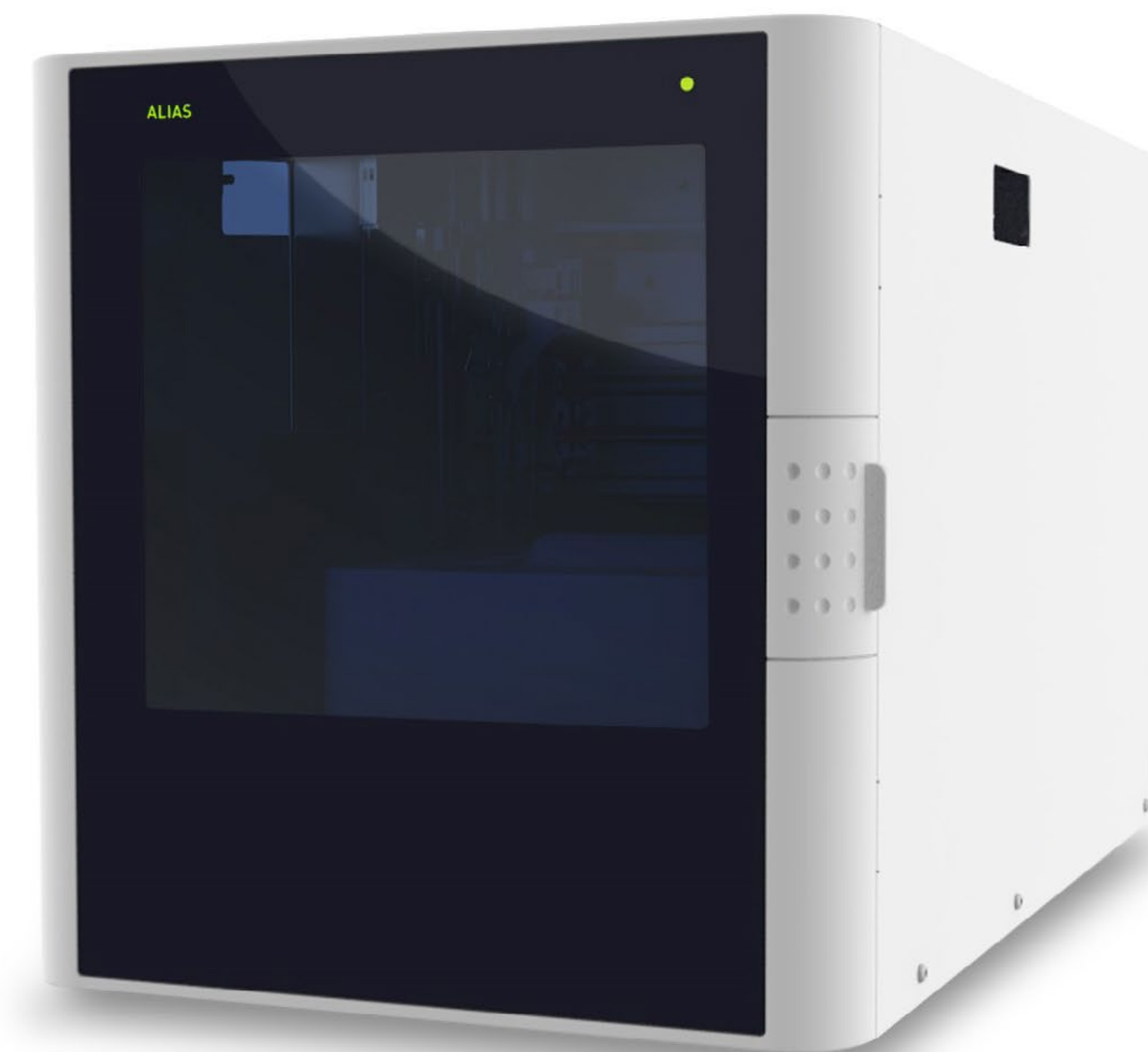

Product Overview



ALIAS™ UHPLC

ALIAS™ is also available as a UHPLC compatible version permitting injection into UHPLC systems operated at pressures as high as 18,000 PSI. A special injection routine has been developed to eliminate influence of sample loop decompression on injection performance. The UHPLC version can also be equipped with sample cooling.

ALIAS™ Prep LC

A special modification for large volume injections turns the ALIAS™ into a perfect injector for your preparative LC system. The ALIAS™ Prep version holds 24 vials of 10 mL and uses a 2.5 mL syringe. Needles, tubing and sample loop have larger capacity and allow rapid injection of sample volumes up to 10 mL.

Features and options

- Metal free sampling with silica-coated steel needle and PEEK valve (option)
- Reagent addition and mix capabilities for derivatization, dilution, internal standard addition
- Optional 6-port solvent selection valve (SVV) for extended selection of reagents for needle wash and reagent addition (option)
- Integrated Stream Switching (ISS): optional extra high pressure 6-port switching valve for column switching or other stream switching applications up to 18,000 PSI
- Quick-fit injection valve for fast service



Specifications

	ALIAS	ALIAS UHPLC
Injection modes	Full-loop Partial loop-fill µL-pick-up	Pressure Assisted Sample Aspiration using ~10 PSI sample headspace pressure to avoid air bubbles in sample lines.
Injection volume	Programmable from 0 µl – 9999 µL 1 µL increments	Max injection volume depends on installed sample loop and injection mode
Injection precision	Full-loop injection < 0.3% RSD Partial loop-fill < 0.5% RSD µL-pick-up < 1.0% RSD	For injection volumes > 5 µL
Sample viscosity	0.1 – 5 cP	
Injections per vial/well	Max 9	
Syringe volume	500 µL standard 250, 1000 and 2500 µL optional	
Needle wash Inside and outside needle wash with drying. Wash can be programmed between injections and between vials/wells.	1 solvent 5 additional wash solvents	Programmable volume from a 250 µL wash reservoir SSV option required
Injection cycle time	< 60 seconds	< 20 seconds, with typical 10 µL injection (loop fill with rinse buffer)
Valve switching time	60 msec	
Wetted parts	SS316, PTFE, TEFLON, VESPEL, glass, For Bio-kit option: PEEK and coated-steel (needle) instead of SS316	
Carry-over	< 0.05% with standard wash Typically < 0.01% with extra wash	“zero carry-over” can be accomplished with ALIAS™ wash capabilities
Sample capacity	Microtiter plates: 2 Vials: 2x 48 (1.5 mL) or 2x 12 (10 mL) – optional	Microtiter plates according to SBS standards. 96-well high and low and 384-well.
Maximum vial/MTP height	47 mm	including cap
Sample cooling Factory installed option (Peltier technology)	Minimum: 4°C ± 2°C Maximum: ambient temp -3°C	Measured as air temperature in sample compartment for maximum ambient temperature 25°C and maximum humidity 80%





HPD™

High Pressure Dispenser

Accurate flow at high pressure

Traditional volumetric dispensers are designed for pipetting reagents or samples into vials or wells at ambient pressure or a few bar at most. On-line volumetric reagent delivery however, may require the ability to introduce reagents into a system with a high working pressure. The HPD™ was originally designed for SPE solvent delivery in on-line SPE-LC systems, but other applications are easy to imagine. Think for example of pre-column reagent addition for on-line derivatization in HPLC and post-column reagent addition for detection enhancement.



Accurate volume
delivery



Backpressure
up to 300 bar



Solvent
pre-mixing



Product
Overview



Specifications

Syringe volume	2 mL
Volume accuracy	± 1.0% (for volumes > 0.3 mL) ± 2.0% (for volumes < 0.3 mL)
Volume precision	< 1.0% RSD (volumes > 0.1 mL)
Flowrate	0.1 - 10 mL/min (aspirate and dispense)
Flow accuracy	+/- 1.0%
Flow precision	< 1.0% RSD
Flow ripple	< 2.0%
Back pressure	max. 300 bar
Default syringe valve	6 port (In, Out and 4 solvents)
Solvent selection manifold (SSM)	Optional, max. 2 additional valves (2 x 6 solvents)
Solvent mixing	Capable of automatic pre-mixing of 2 solvents
Pressure read-out	Selectable: bar - psi - Mpa
Wetted materials	SS316, Teflon, Tefzel, Kalrez, PE, PEEK

Accurate flow at high pressure

Accurately dispense any volume at your desired flowrate without backpressure dependency up to 300 bar. Whether you require small or large volumes, solvents will be delivered in a very accurate and precise manner. This makes the HPD™ very suitable for online addition of reagent or pumping large sample volumes.

Solvent pre-mixing

The HPD™ is capable of automatic pre-mixing any solvent composition you would like to apply. This makes the instrument a very helpful tool in finding the sweet spot of your application. Just select the solvent composition you want to test and the experiment begins without any laborious manual steps!



DBS Autosampler™

A revolution in DBS sampling

Dried blood spot (DBS) sampling is an emerging technology for bioanalysis, offering easy, convenient cost effective sample collection, transport and storage. It also offers the possibility for patients who require regular monitoring to take their own blood samples in the comfort of their own home, saving patient stress, transport costs, clinic resources and provides a convenient sampling option in remote locations where medical facilities are not readily available. Our DBS Autosampler™ uses a leak-tight clamp to directly desorb dried blood spots or dried matrix spots as a liquid sample for analysis. Enabling a completely automated workflow for DBS analysis.

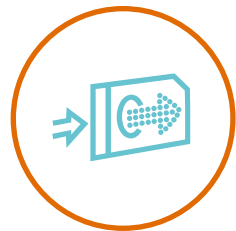
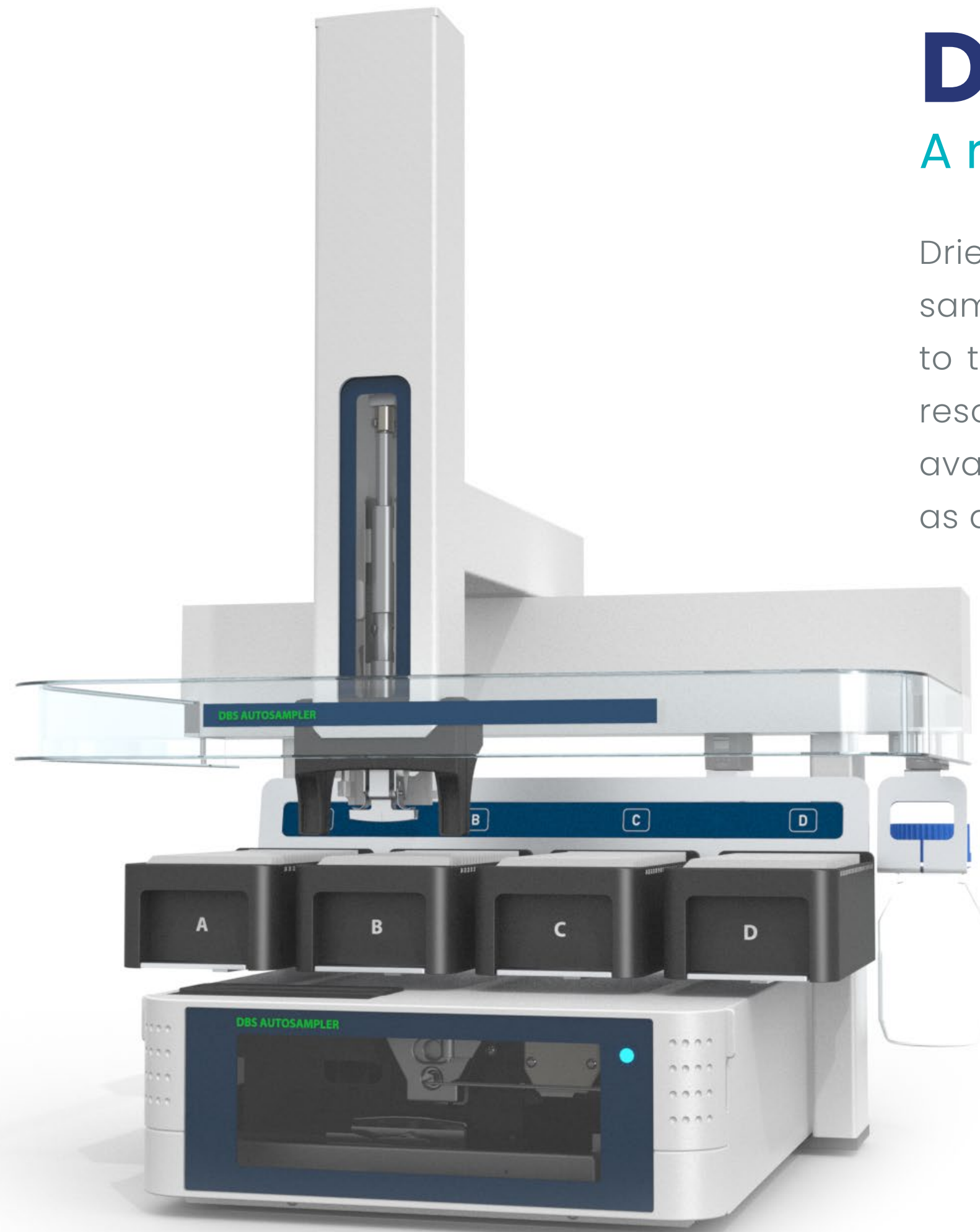

Flow-through desorption (FTD™) technology



No disc punching

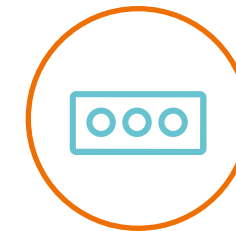

Dried matrix sampling



Automation of the entire workflow



FTD™ – Flow-through Desorption

No manual intervention required with our patented FTD technology. Direct elution of DBS from cards enables optional on-line clean-up and analyte separation by SPE prior to analysis in an automated workflow. Replaceable clamp head sizes of 2, 4, 6 or 8 mm clamp and seal filter paper cards up to pressures of about 200 bar (up to 100 bar for the 8 mm clamp). Desorption solvent is delivered by a high pressure dispenser (HPD™).

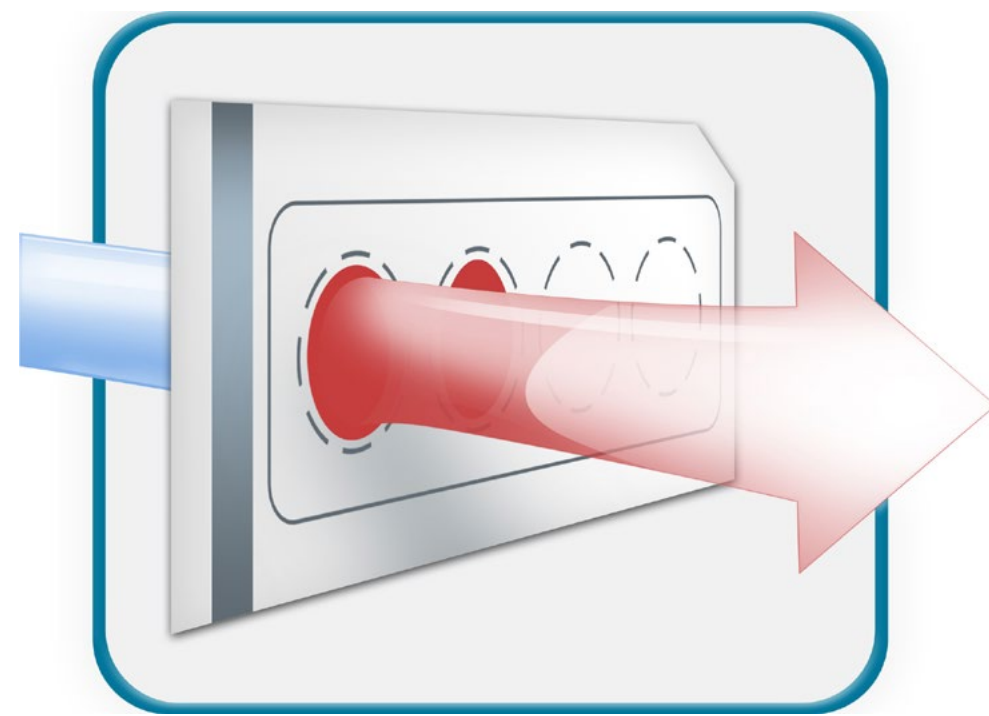

IVC™ – Intelligent Vision Camera

Accurate spot positioning and sample traceability is vital for accuracy. Our camera has been designed so that it not only provides accurate positioning of DBS cards in the high pressure clamp for direct, flowthrough desorption of bloodspots; but also offers sample barcode identification for 1D or 2D barcodes, full or partial spot desorption options and full image capture for sample information storage, tracking and traceability.



AISA™ – Automated Internal Standard Addition

Accurate automated internal standard addition using a loop injection method. A specified volume of internal standard is loaded in a loop using an integrated mini pump. The internal standard is then added to the sample during desorption of a blood spot using a high pressure dispenser (HPD™).

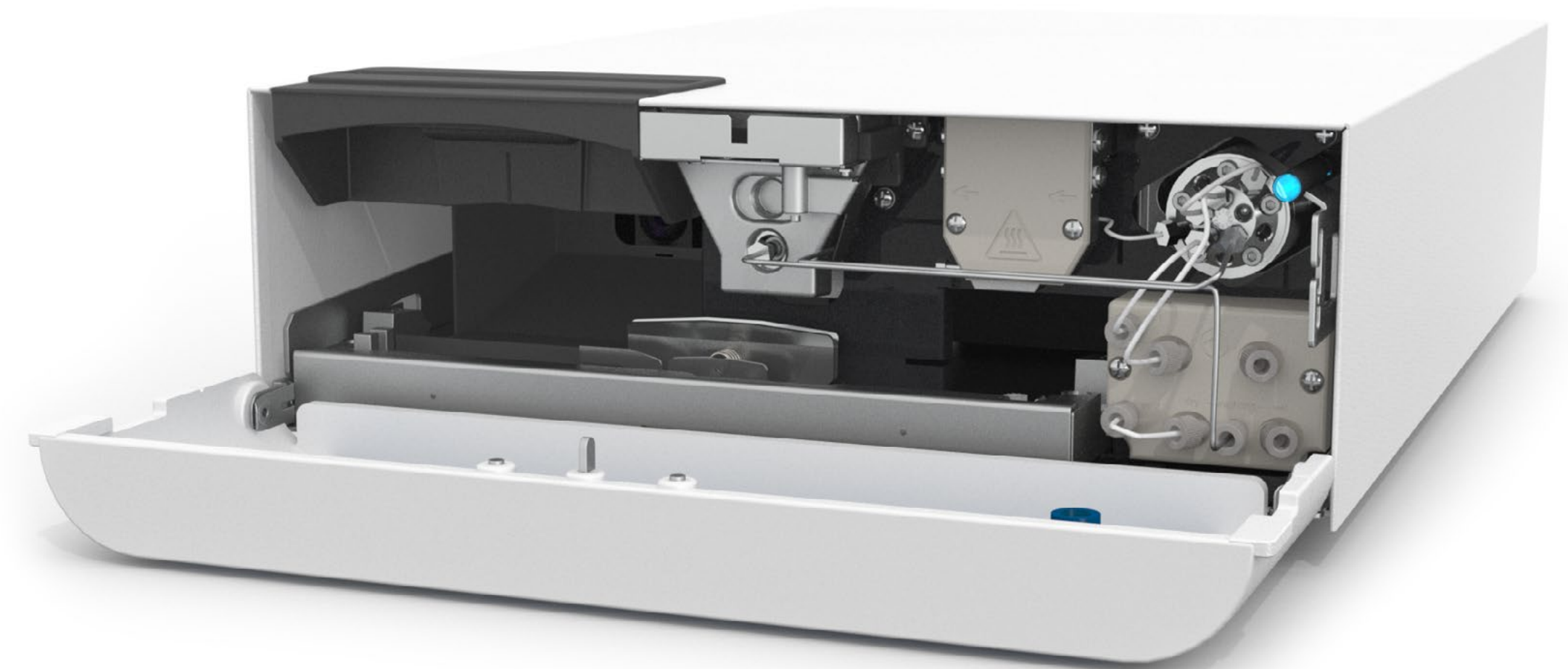

Specifications

Flow-through desorption concept (FTD™)	Leak-tight clamp heads provide direct elution of DBS from cards without punching discs.
Desorption methods	Partial spot, full spot.
Clamp heads	Replaceable. Sizes (2 mm, 4 mm, 6 mm and 8 mm available). SS316. Leak-tight up to 200 bar for 2 mm, 4 mm and 6 mm clamp heads. Leak-tight up to 100 bar for 8 mm clamp head. Programmable clamping force 300 – 3000 N.
Sample capacity	4 spot Whatman or PerkinElmer type DBS card in a cassette format, with an extended capacity of up to 96 DBS cards, or 384 samples.
Intelligent Vision Camera (IVC™)	Camera designed to provide <ul style="list-style-type: none"> - missing card detection - accurate positioning of DBS cards in the clamp - 1D and 2D sample barcode identification - full or partial spot desorption options - full image capture for sample information storage, tracking and traceability.
Internal standard loop	20 µL.
IS pump	Internal standard pump max. 95 µL/sec.
Compressor	To dry fluid lines and clamp heads after desorption and wash.
Clamp positioning precision	0.2 mm.
Injection valve	SS stator and PEEK rotor seal, bore 0.25 mm, 1/16" connection ports, except port 4 (1/32" connection port).
Valve switching time	<100 msec.
Reproducibility desorption	RSD < 1%; Due to paper quality larger values are typically obtained.
Reproducibility internal standard	RSD < 1%.
Cycle time, typical using HPD™	150 sec including desorption and wash.
Cycle time, from card retrieval to ready to desorb	20 sec.
Wetted parts in sample flow path	SS316, PTFE, PEEK.
Wetted parts in dispenser and wash lines	Tefzel, Teflon, PEEK, Kelf, Glass.



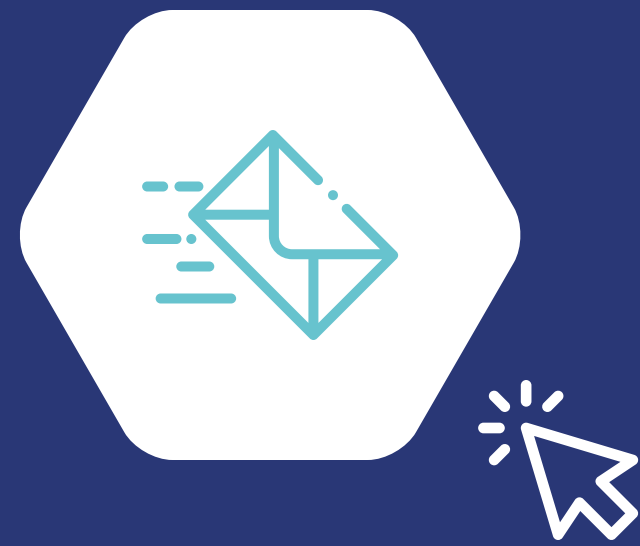

Get in touch

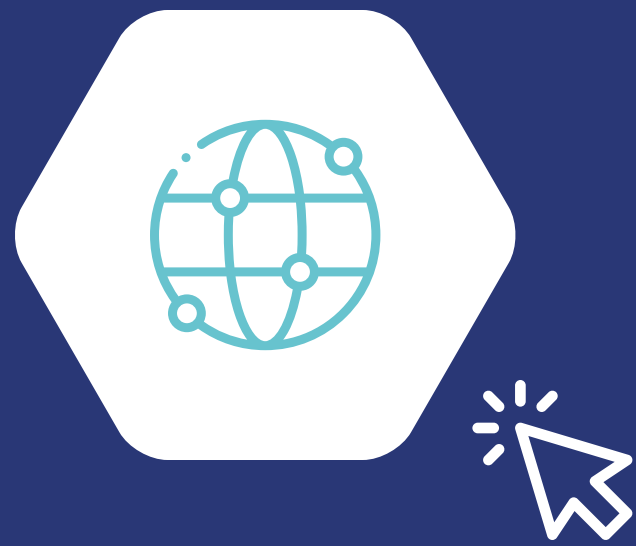

Visit our website



Our technologies

Spark
H O L L A N D

Waanderweg 40 | 7812 HZ EMMEN | The Netherlands

Phone: +31 591 631700 | Fax: +31 591 630035 | E-mail: sales@sparkholland.com